

Self-aligning linear ball bearings

Light range – metric sizes

SCHAEFFLER GROUP
INDUSTRIAL

www.bearing-spb.ru

Contents

Page	
3	Self-aligning linear ball bearings
6	Shafts
7	Design of bearing arrangements
8	Dimension tables “Self-aligning linear ball bearings”
10	Dimension tables “Linear ball bearing units”
22	Dimension tables “Shafts”

Self-aligning linear ball bearings



Features

Self-aligning linear ball bearings

- are units comprising a housing, movable segments and seals
 - housing in closed or open design
 - segments comprise a segment upper section, load plate, rolling elements (balls) and a segment lower section including the ball recirculation tracks
- automatically compensate misalignments of the bearing central axis due to the movable segments. Shaft misalignments of up to max. ± 40 angular minutes are therefore possible without impairing the bearing load carrying capacity or operating life
- have no reduction in load ratings due to edge pressure within the shaft misalignment tolerance, and can therefore support considerably higher loads than non-aligning linear ball bearings of the same diameter
- run very quietly and with very low friction due to
 - the automatic compensation of misalignments
 - ground rolling element raceways in the load plates
- run without stick-slip – as compared with plain bearings – and are therefore suitable even for applications requiring high positional accuracy
- allow high speeds up to 5 m/s and accelerations up to 100 m/s^2
- allow the construction of linear guidance systems with unlimited travel
- are sealed on both sides by gap seals or contact seals with a floating support arrangement
 - open linear ball bearings also have integral sealing strips on both sides
- sealed versions are supplied greased and are maintenance-free in many applications due to the integral lubricant reservoir
- are dimensioned so that they can replace conventional linear ball bearings even in existing applications
- can be supplied combined with housings as housing units
- are suitable for use with supported shafts in the open version and with the appropriate housing
- have adjustable clearance and can be preloaded in conjunction with open, slotted housings
- can be combined with INA housings and shafts or shaft and support rail units to achieve optimally matched, ready-to-fit, particularly cost-effective complete linear solutions with a long operating life
- are also produced in inch dimensions (series KX, KXO, see *INA Market Information MAI 70*).

Self-aligning linear ball bearings



KS
KS..-PP



①



②



KSO
KSO..-PP



①



②

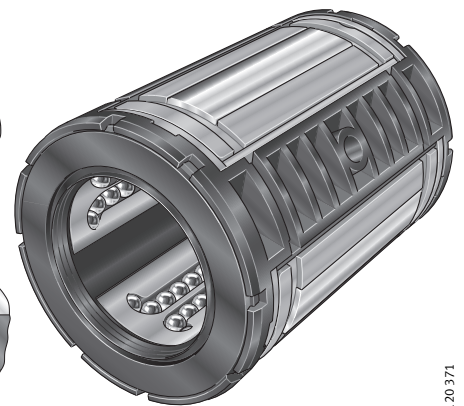

120 371

- self-aligning linear ball bearings, closed design
- KS with gap seals ① on both sides
- KS..-PP with lip seals ② on both sides
- for operating temperatures up to $+80 \text{ }^\circ\text{C}$
- for shaft diameters from 12 mm to 50 mm

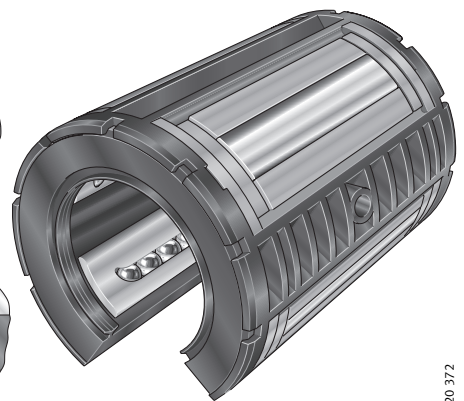

120 372

- self-aligning linear ball bearings, open design, for supported shafts
- KSO with gap seals ① on both sides
- KSO..-PP with lip seals ② on both sides
- integral gap type sealing strips
- for operating temperatures up to $+80 \text{ }^\circ\text{C}$
- for shaft diameters from 12 mm to 50 mm

Self aligning linear ball bearings

Units – tandem arrangement



**KTSG
KTSS**

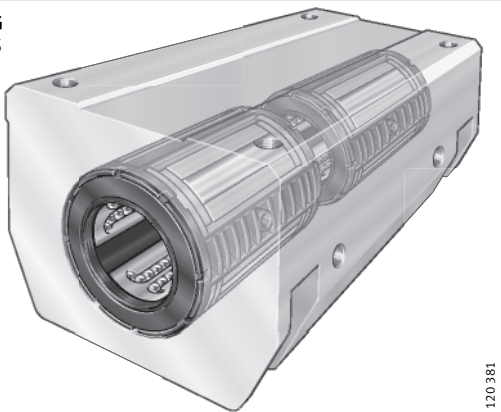

120 381

- housing made from high strength aluminium alloy, fitted with two self-aligning linear ball bearings KS...-PP in tandem arrangement, bearings can be relubricated
- KTSS slotted and with adjustable clearance
- for operating temperatures up to +80 °C
- for shaft diameters from 12 mm to 30 mm



14

Units



**KGSNG
KGSNS**

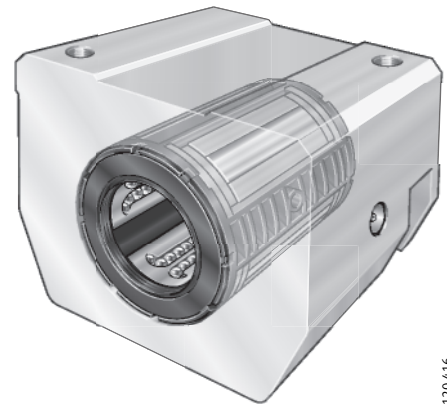

120 416

- housing made from high strength aluminium alloy, fitted with self-aligning linear ball bearing KS...-PP, bearing can be relubricated
- KGSNS slotted and with adjustable clearance
- for operating temperatures up to +80 °C
- for shaft diameters from 12 mm to 50 mm



10



**KTSO
KTSOS**

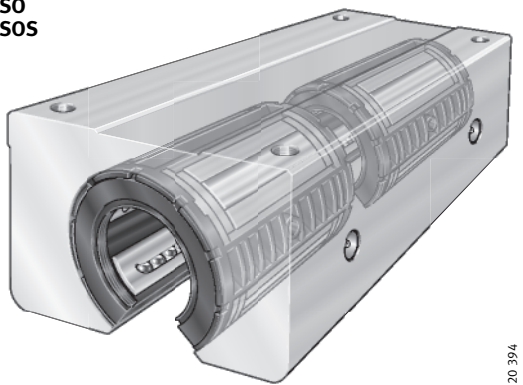

120 394

- housing made from high strength aluminium alloy, open design, suitable for supported shafts, fitted with two self-aligning linear ball bearings KSO...-PP in tandem arrangement, bearings can be lubricated
- KTSOS slotted and with adjustable clearance
- for operating temperatures up to +80 °C
- for shaft diameters from 12 mm to 30 mm



16



**KGSC
KGSCS**

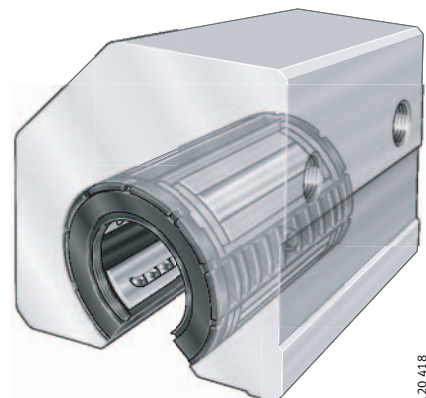

120 418

- housing made from high strength aluminium alloy, open design, suitable for supported shafts, fitted with self-aligning linear ball bearing KSO...-PP, bearing can be lubricated
- KGSCS slotted and with adjustable clearance
- for operating temperatures up to +80 °C
- for shaft diameters from 20 mm to 50 mm



18

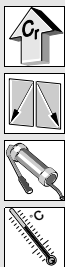

**KGSNO
KGSNOS**

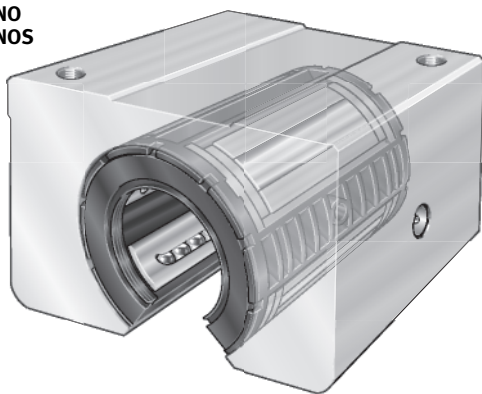

120 417

- housing made from high strength aluminium alloy, open design, suitable for supported shafts, fitted with self-aligning linear ball bearing KSO...PP, bearing can be lubricated
- KGSNOS slotted and with adjustable clearance
- for operating temperatures up to +80 °C
- for shaft diameters from 12 mm to 50 mm



12

Units – tandem arrangement



KTFS

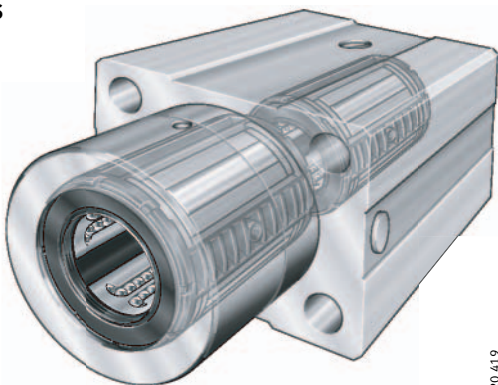

120 419

- housing made from high strength aluminium alloy, fitted with two self-aligning linear ball bearings KS...PP in tandem arrangement, bearings can be relubricated
- for operating temperatures up to +80 °C
- for shaft diameters from 12 mm to 30 mm



20

Shafts



Features

Shafts

- are precision raceways for INA linear ball bearings
- are made from quenched and tempered steel with a surface hardness of 670 HV + 170 HV (59 HRC + 6 HRC)
 - the uniform hardness depth ensures a smooth transition from the hardened surface layer to the tough core
- can be loaded up to the full basic load rating of INA self-aligning linear ball bearings
- are produced as standard in tolerance class h6
- have high accuracy (roundness and parallelism)
- can be supplied in single pieces up to 6 000 mm in length – depending on the diameter
 - longer lengths are available by agreement
 - the shaft ends are chamfered after cutting to length
- can also be supplied in a special version with ends that differ from the standard version
- can be produced with axial or radial threaded holes for fixing (see *Threaded holes*)
- allow the construction of linear guidance systems with high load carrying capacity, high rigidity, high accuracy and a long operating life
- can be combined with INA linear ball bearings or INA linear ball bearing units to achieve optimally matched, ready-to-fit, particularly cost-effective shaft guidance systems
- are used not only as raceways for INA linear ball bearings but also as:
 - guide rods for plain bushes
 - column guides for stud and yoke type track rollers
 - drawing and straightening rollers
 - shafts and axles in a wide variety of different applications.

Shafts



W

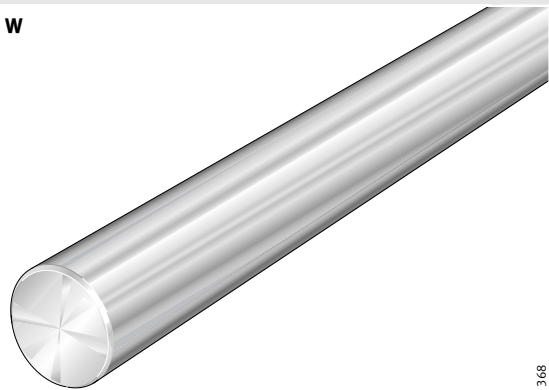

120 368

- high precision solid shaft made from quenched and tempered steel
- standard tolerance h6
 - special tolerances available by agreement
- diameters from 5 mm to 80 mm



22

Threaded holes

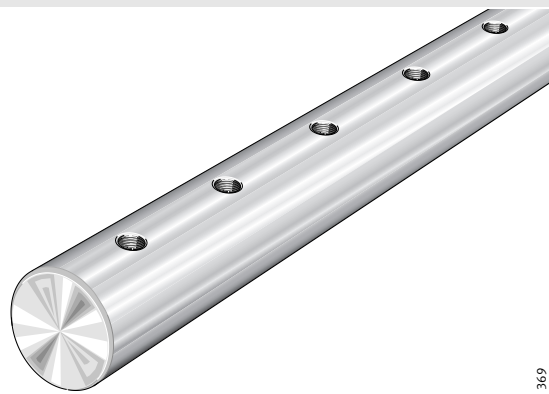

120 369

- recommended radial and axial threaded holes for fixing of high precision solid shafts W
 - for possible combinations see *Dimension table*
- shaft diameters from 5 mm to 80 mm



23

Design of bearing arrangements

Operating clearance

The operating clearance of linear bearings is defined by the selection of shaft and housing tolerances.

The operating clearance of linear bearing and housing units is either defined by shaft selection or, in the case of split housings, is set using the adjusting screw.

If the housings are not rigid, tests must be carried out to determine the housing and shaft tolerance required to achieve the required operating clearance.

Light range

Bearings KS, KS..-PP, KSO, KSO..-PP:

Slight preload is achieved with shafts to h6 and a housing bore to H7.

Units KTSG, KTSO, KGSNG, KGSC, KGSNO, KTFS:

Slight preload is achieved with shafts to h6.

Units KTSS, KTSOS, KGSNS, KGSCS, KGSNOS:

The clearance can be adjusted using a screw.

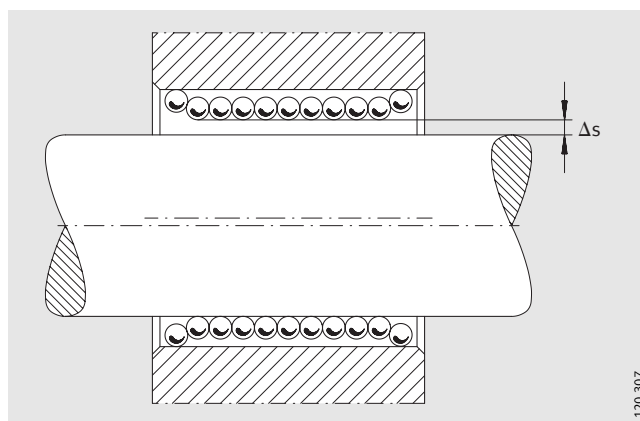

Figure 1 - Operating clearance

Self-aligning linear ball bearings

Light range – metric sizes

closed and open designs
gap seals or
contact seals on both sides

Series KS
KS...-PP
KSO
KSO...-PP

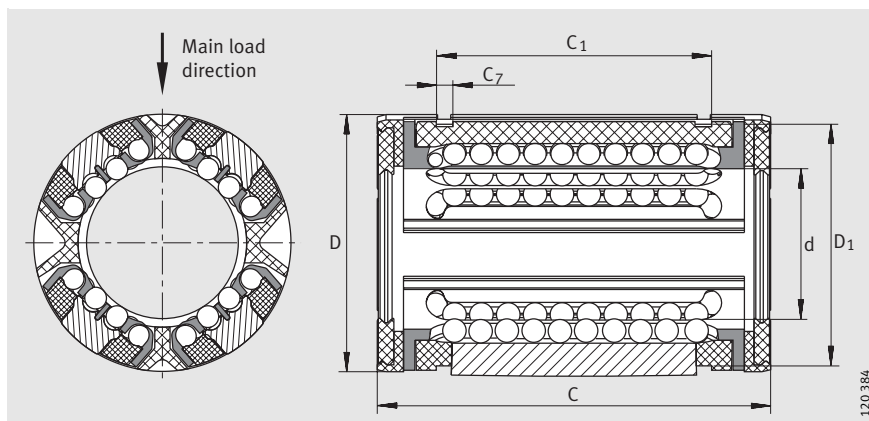

KS, KS...-PP

Dimension table · Dimensions in mm

Shaft diameter d	Series				Mass m ≈kg	Dimensions			Mounting dimensions	
	KS ¹⁾	KS...-PP ²⁾	KSO ¹⁾	KSO...-PP ²⁾		d	D	C	A ₆ ³⁾	C ₁
12	KS12	KS12-PP	–	–	0,018	12	22	32	–	22,6
	–	–	KSO12	KSO12-PP	0,013	12	22	32	7,6	–
16	KS16	KS16-PP	–	–	0,028	16	26	36	–	24,6
	–	–	KSO16	KSO16-PP	0,019	16	26	36	10,1	–
20	KS20	KS20-PP	–	–	0,051	20	32	45	–	31,2
	–	–	KSO20	KSO20-PP	0,038	20	32	45	10	–
25	KS25	KS25-PP	–	–	0,102	25	40	58	–	43,7
	–	–	KSO25	KSO25-PP	0,075	25	40	58	12,5	–
30	KS30	KS30-PP	–	–	0,172	30	47	68	–	51,7
	–	–	KSO30	KSO30-PP	0,135	30	47	68	14,3	–
40	KS40	KS40-PP	–	–	0,335	40	62	80	–	60,3
	–	–	KSO40	KSO40-PP	0,259	40	62	80	18,2	–
50	KS50	KS50-PP	–	–	0,589	50	75	100	–	77,3
	–	–	KSO50	KSO50-PP	0,454	50	75	100	22,7	–

1) Gap seals on both sides.

2) Contact seals on both sides.

3) Dimension A₆ on diameter d.

4) Hole arrangement symmetrical with bearing width C.

5) The basic load ratings apply only to hardened (670 HV + 170 HV) and ground shaft raceways. Basic load ratings in accordance with DIN 636-1.

6) Basic load rating in main load direction.

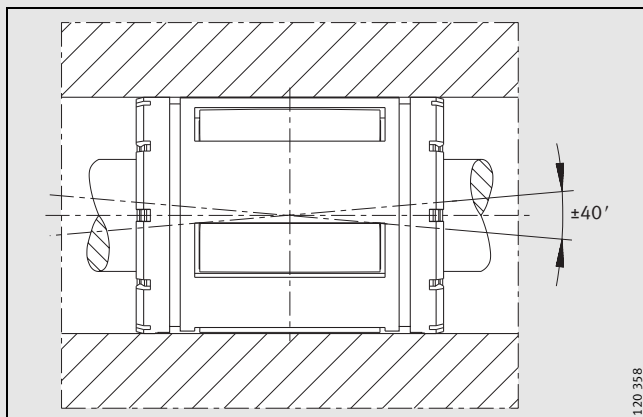

Compensation of misalignments ±40'

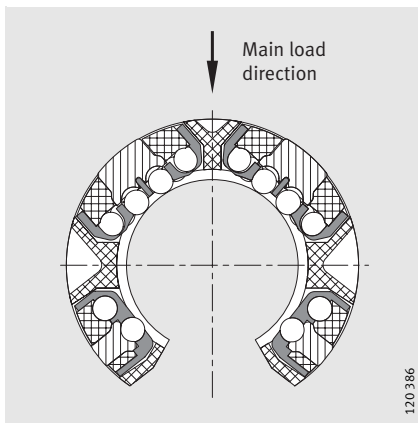

KSO, KSO..-PP
Main load direction

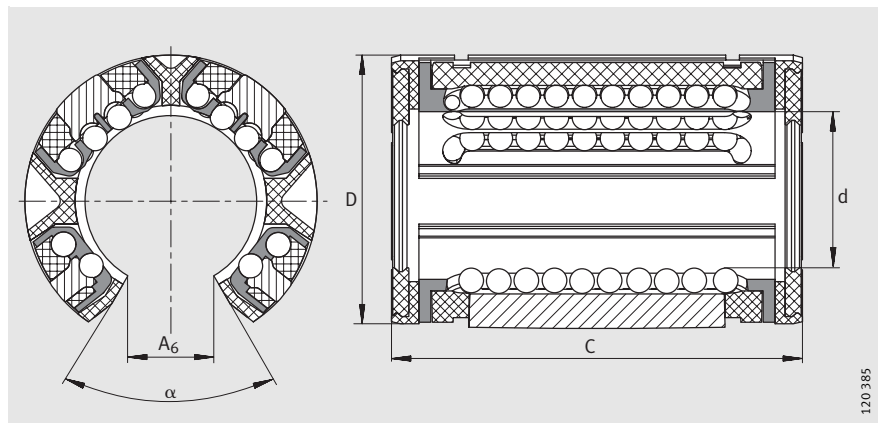

KSO, KSO..-PP

C ₇	D ₁	H ₁₀	K ₁ ⁴⁾	K ₄ ⁴⁾	α Degrees	Ball rows Quantity	Basic load ratings ⁵⁾⁶⁾		Suitable snap ring to DIN 471	Shaft diameter d
							dyn. C _{max} kN	stat. C _{0 max} kN		
1,3	21	-	3	-	-	8	0,9	0,81	22×1,2	12
-	-	-	3	3	78	6	0,9	0,81	-	
1,3	25	-	3	-	-	8	1,43	1,16	26×1,2	16
-	-	-	3	3	78	6	1,43	1,16	-	
1,6	30,7	-	3	-	-	8	2,2	1,73	32×1,5	20
-	-	-	3	3	60	6	2,2	1,73	-	
1,85	38	-	3,5	-	-	8	3,95	3,25	42×1,75	25
-	-	1,5	3,5	3	60	6	3,95	3,25	-	
1,85	44,7	-	3,5	-	-	8	5,9	4,5	48×1,75	30
-	-	2	3,5	3	57	6	5,9	4,5	-	
2,15	59,4	-	3,5	-	-	8	10,2	7,2	63×2	40
-	-	1,5	3,5	3	54	6	10,2	7,2	-	
2,65	71,4	-	4,5	-	-	8	15,1	10,4	75×2,5	50
-	-	2,5	4,5	5	54	6	15,1	10,4	-	

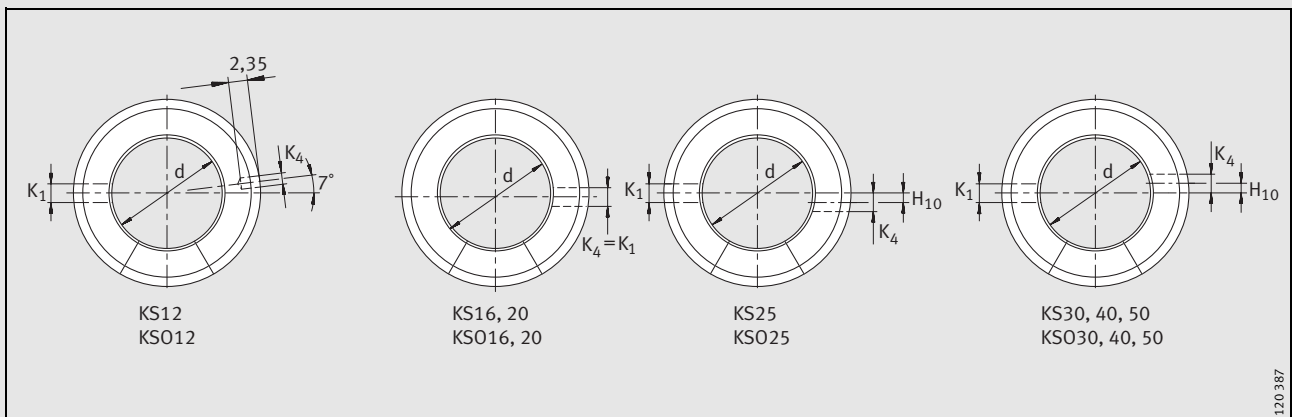

Fixing holes

Linear ball bearing units

Light range – metric sizes

sealed, greased,
with relubrication facility

Series KGSNG...-PP-AS
KGSNS...-PP-AS

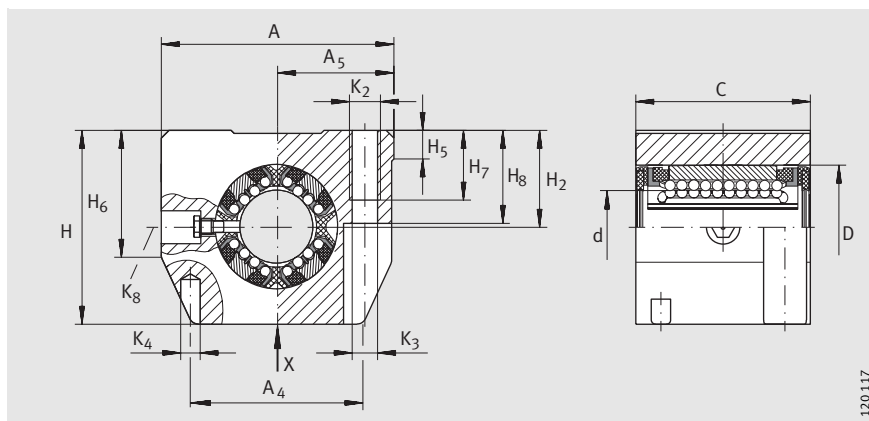

KGSNG...-PP-AS

120117

Dimension table · Dimensions in mm

Shaft diameter d	Series		Mass m ≈ kg	Dimensions				Mounting dimensions				
	KGSNG...-PP-AS	KGSNS...-PP-AS		d	A	C	H	A ₁	A ₄	A ₅	C ₂ ¹⁾	D
	Designation	Designation						±0,15		±0,01	±0,15	
12	KGSNG12-PP-AS	–	0,1	12	43	32	35	32	34	21,5	23	22
	–	KGSNS12-PP-AS	0,1	12	43	32	35	32	34	21,5	23	22
16	KGSNG16-PP-AS	–	0,17	16	53	37	42	40	40	26,5	26	26
	–	KGSNS16-PP-AS	0,17	16	53	37	42	40	40	26,5	26	26
20	KGSNG20-PP-AS	–	0,27	20	60	45	50	45	44	30	32	32
	–	KGSNS20-PP-AS	0,27	20	60	45	50	45	44	30	32	32
25	KGSNG25-PP-AS	–	0,56	25	78	58	60	60	59,4	39	40	40
	–	KGSNS25-PP-AS	0,56	25	78	58	60	60	59,4	39	40	40
30	KGSNG30-PP-AS	–	0,83	30	87	68	70	68	63	43,5	45	47
	–	KGSNS30-PP-AS	0,83	30	87	68	70	68	63	43,5	45	47
40	KGSNG40-PP-AS	–	1,55	40	108	80	90	86	76	54	58	62
	–	KGSNS40-PP-AS	1,55	40	108	80	90	86	76	54	58	62
50	KGSNG50-PP-AS	–	2,7	50	132	100	105	108	90	66	50	75
	–	KGSNS50-PP-AS	2,7	50	132	100	105	108	90	66	50	75

1) Dimension C₂ and lubrication hole symmetrical with bearing width C.

2) For fixing screws to EN ISO 4762-8.8.

If there is a possibility of settling, the fixing screws should be secured against rotation.

3) Centring for dowel hole.

4) The basic load ratings apply only to hardened (670 HV + 170 HV) and ground shaft raceways.

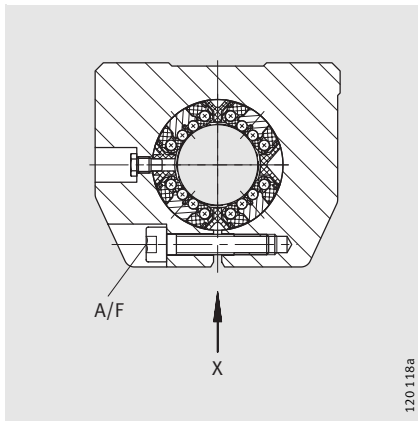

KGSNS..-PP-AS

120 118a

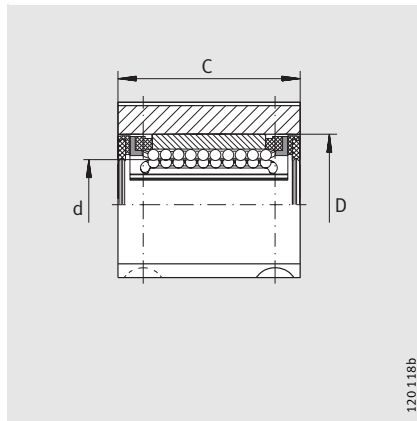

120 118b

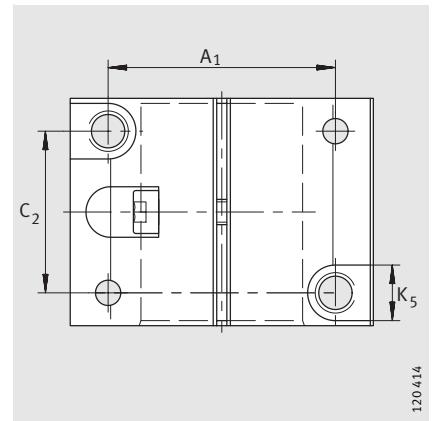

View X (rotated 90°)

120 414

H ₂ +0,008 -0,016	H ₅	H ₆	H ₇	H ₈	K ₂	K ₃ ²⁾	K ₄ ³⁾	K ₅ ²⁾	K ₈ ¹⁾	A/F	Ball rows Quantity	Basic load ratings ⁴⁾		Shaft diameter d
												dyn. C _{max} kN	stat. C _{0 max} kN	
18	5,4	25,3	11	16,5	M 5	4,3	4	8	NIP 4 MZ	–	8	0,9	0,81	12
18	5,4	25,3	11	16,5	M 5	4,3	4	8	NIP 4 MZ	2,5	8	0,9	0,81	
22	6,9	28	13	21	M 6	5,3	4	10	NIP 4 MZ	–	8	1,43	1,16	16
22	6,9	28	13	21	M 6	5,3	4	10	NIP 4 MZ	3	8	1,43	1,16	
25	7,4	32,8	18	24	M 8	6,6	5	11	NIP 4 MZ	–	8	2,2	1,73	20
25	7,4	32,8	18	24	M 8	6,6	5	11	NIP 4 MZ	4	8	2,2	1,73	
30	8,3	40	22	29	M10	8,4	6	15	NIP 5 MZ	–	8	3,95	3,25	25
30	8,3	40	22	29	M10	8,4	6	15	NIP 5 MZ	5	8	3,95	3,25	
35	9,3	44,7	22	34	M10	8,4	6	15	NIP 5 MZ	–	8	5,9	4,5	30
35	9,3	44,7	22	34	M10	8,4	6	15	NIP 5 MZ	5	8	5,9	4,5	
45	11,7	55,9	26	44	M12	10,5	8	18	NIP 5 MZ	–	8	10,2	7,2	40
45	11,7	55,9	26	44	M12	10,5	8	18	NIP 5 MZ	6	8	10,2	7,2	
50	10,6	60	35	49	M16	13,5	10	20	NIP 6 MZ	–	8	15,1	10,4	50
50	10,6	60	35	49	M16	13,5	10	20	NIP 6 MZ	8	8	15,1	10,4	

Linear ball bearing units

Light range – metric sizes

sealed, greased,
with relubrication facility

Series KGSNO...-PP-AS
KGSNOS...-PP-AS

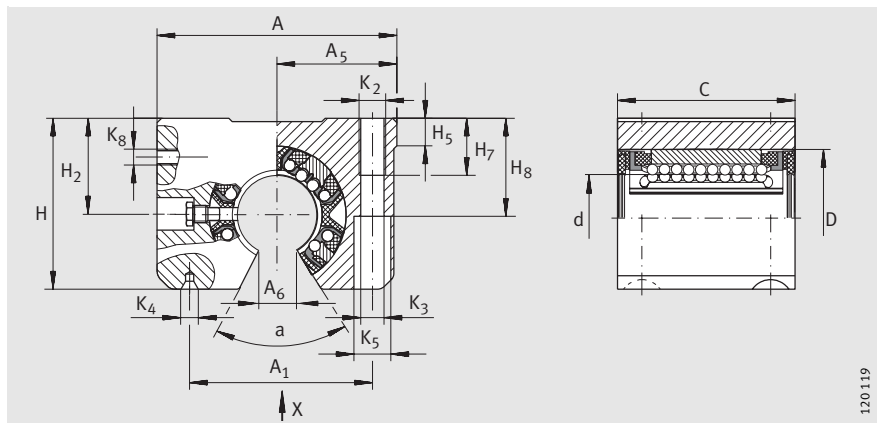

KGSNO...-PP-AS

120119

Dimension table · Dimensions in mm

Shaft diameter d	Series		Mass m ≈kg	Dimensions				Mounting dimensions				
	KGSNO...-PP-AS Designation	KGSNOS...-PP-AS Designation		d	A	C	H	A ₁ ±0,15	A ₅ ±0,01	A ₆ ¹⁾	C ₂ ²⁾ ±0,15	D
12	KGSNO12-PP-AS	–	0,09	12	43	32	28	32	21,5	7,6	23	22
	–	KGSNOS12-PP-AS	0,09	12	43	32	28	32	21,5	7,6	23	22
16	KGSNO16-PP-AS	–	0,15	16	53	37	35	40	26,5	8,9	26	26
	–	KGSNOS16-PP-AS	0,15	16	53	37	35	40	26,5	8,9	26	26
20	KGSNO20-PP-AS	–	0,25	20	60	45	42	45	30	9,2	32	32
	–	KGSNOS20-PP-AS	0,25	20	60	45	42	45	30	9,2	32	32
25	KGSNO25-PP-AS	–	0,52	25	78	58	51	60	39	11,9	40	40
	–	KGSNOS25-PP-AS	0,52	25	78	58	51	60	39	11,9	40	40
30	KGSNO30-PP-AS	–	0,76	30	87	68	60	68	43,5	14,3	45	47
	–	KGSNOS30-PP-AS	0,76	30	87	68	60	68	43,5	14,3	45	47
40	KGSNO40-PP-AS	–	1,4	40	108	80	77	86	54	18,8	58	62
	–	KGSNOS40-PP-AS	1,4	40	108	80	77	86	54	18,8	58	62
50	KGSNO50-PP-AS	–	2,4	50	132	100	88	108	66	22,7	50	75
	–	KGSNOS50-PP-AS	2,4	50	132	100	88	108	66	22,7	50	75

1) Dimension A₆ on diameter d.

2) Dimension C₂ and lubrication hole symmetrical with bearing width C.

3) For fixing screws to EN ISO 4762-8.8.

If there is a possibility of settling, the fixing screws should be secured against rotation.

4) The basic load ratings apply only to hardened (670 HV + 170 HV) and ground shaft raceways.

5) Centring hole to DIN 332, type A.

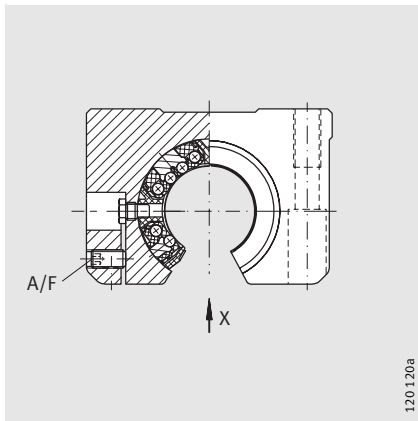

KGSNOS...PP-AS

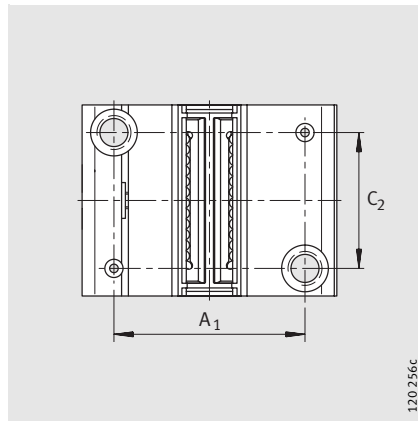

View X (rotated 90°)

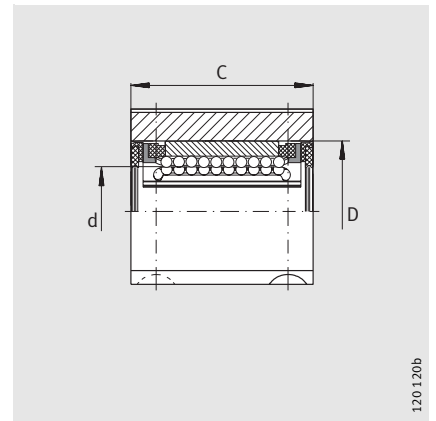

120 120b

H ₂ +0,008 -0,016	H ₅	H ₇	H ₈	K ₂	K ₃ ³⁾	K ₄ ⁵⁾	K ₅ ³⁾	K ₈ ²⁾	A/F	α Degrees	Ball rows Quantity	Basic load ratings ⁴⁾		Shaft diameter d
												dyn. C _{max} kN	stat. C _{0 max} kN	
18	6,1	11	16,5	M 5	4,3	1,6 × 3,35	8	NIP 4 MZ	–	78	6	0,9	0,81	12
18	6,1	11	16,5	M 5	4,3	1,6 × 3,35	8	NIP 4 MZ	2,5	78	6	0,9	0,81	
22	7,5	13	21	M 6	5,3	1,6 × 3,35	10	NIP 4 MZ	–	68	6	1,43	1,16	16
22	7,5	13	21	M 6	5,3	1,6 × 3,35	10	NIP 4 MZ	2,5	68	6	1,43	1,16	
25	8	18	24	M 8	6,6	2 × 4,25	11	NIP 4 MZ	–	55	6	2,2	1,73	20
25	8	18	24	M 8	6,6	2 × 4,25	11	NIP 4 MZ	2,5	55	6	2,2	1,73	
30	8,8	22	29	M10	8,4	2,5 × 5,3	15	NIP 5 MZ	–	57	6	3,95	3,25	25
30	8,8	22	29	M10	8,4	2,5 × 5,3	15	NIP 5 MZ	3	57	6	3,95	3,25	
35	9,7	22	34	M10	8,4	2,5 × 5,3	15	NIP 5 MZ	–	57	6	5,9	4,5	30
35	9,7	22	34	M10	8,4	2,5 × 5,3	15	NIP 5 MZ	3	57	6	5,9	4,5	
45	12,4	26	44	M12	10,5	3,15 × 6,7	18	NIP 5 MZ	–	56	6	10,2	7,2	40
45	12,4	26	44	M12	10,5	3,15 × 6,7	18	NIP 5 MZ	4	56	6	10,2	7,2	
50	11,1	35	49	M16	13,5	4 × 8,5	20	NIP 6 MZ	–	54	6	15,1	10,4	50
50	11,1	35	49	M16	13,5	4 × 8,5	20	NIP 6 MZ	5	54	6	15,1	10,4	

Linear ball bearing units

closed and open designs
contact seals on both sides

Series KTSG...-PP-AS
KTSS...-PP-AS

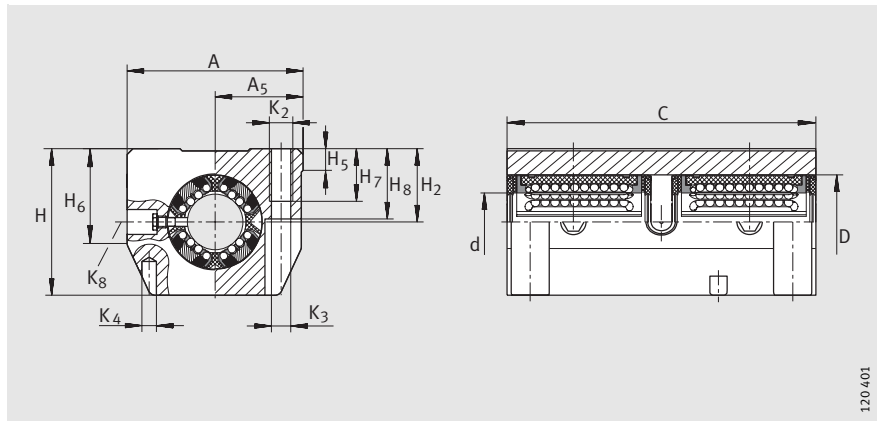

KTSG...-PP-AS

Dimension table · Dimensions in mm

Shaft diameter d	Series		Mass m ≈ kg	Dimensions				Mounting dimensions				
	KTSG...-PP-AS	KTSS...-PP-AS		d	A	C	H	A ₁	A ₅	C ₂ ¹⁾	C ₃ ¹⁾	D
	Designation	Designation						±0,15	±0,01	±0,15		
12	KTSG12-PP-AS	–	0,21	12	43	70	35	32	21,5	56	24	22
	–	KTSS12-PP-AS	0,21	12	43	70	35	32	21,5	56	24	22
16	KTSG16-PP-AS	–	0,38	16	53	78	42	40	26,5	64	26	26
	–	KTSS16-PP-AS	0,38	16	53	78	42	40	26,5	64	26	26
20	KTSG20-PP-AS	–	0,55	20	60	96	50	45	30	76	33	32
	–	KTSS20-PP-AS	0,55	20	60	96	50	45	30	76	33	32
25	KTSG25-PP-AS	–	1,13	25	78	122	60	60	39	94	44	40
	–	KTSS25-PP-AS	1,13	25	78	122	60	60	39	94	44	40
30	KTSG30-PP-AS	–	1,78	30	87	142	70	68	43,5	106	54	47
	–	KTSS30-PP-AS	1,78	30	87	142	70	68	43,5	106	54	47

1) Dimensions and lubrication hole symmetrical with bearing width C.

2) For fixing screws to EN ISO 4762-8.8.
If there is a possibility of settling, the fixing screws should be secured against rotation.

3) Centring for dowel hole.

4) Lubrication nipple.

5) The basic load ratings apply only to hardened (670 HV + 170 HV) and ground shaft raceways.
Basic load ratings in accordance with DIN 636-1.

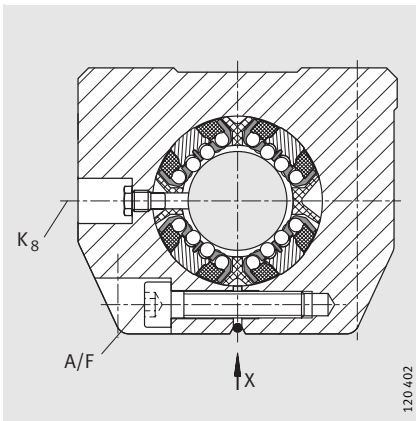

KTSS...-PP-AS
(same dimensions as KTSG...-PP-AS)

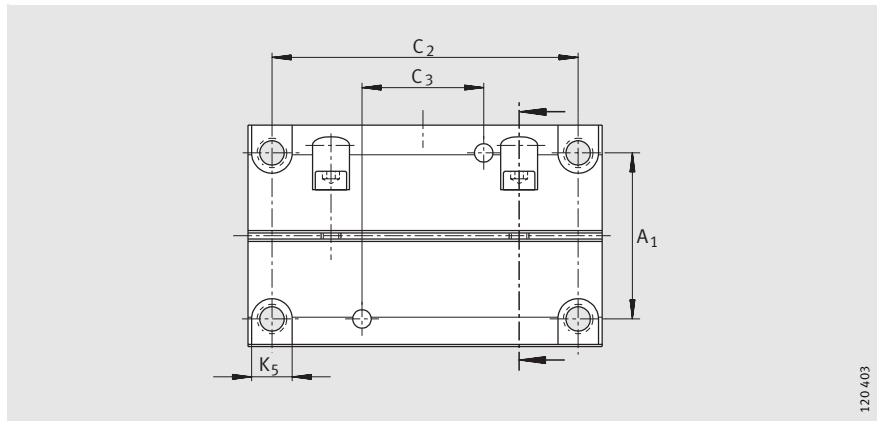

View X (rotated 90°)

H ₂ +0,008 -0,016	H ₅	H ₆	H ₇	H ₈	K ₂	K ₃ ²⁾	K ₄ ³⁾	K ₅ ²⁾	K ₈ ⁴⁾	A/F	Ball rows Quantity	Basic load ratings ⁵⁾		Shaft diameter d
												dyn. C _{max} kN	stat. C _{0max} kN	
18	6	25,3	11	16,5	M 5	4,3	4	8	NIP 4 MZ	–	8	1,46	1,62	12
18	6	25,3	11	16,5	M 5	4,3	4	8	NIP 4 MZ	2,5	8	1,46	1,62	
22	7,5	28	13	21	M 6	5,3	4	10	NIP 4 MZ	–	8	2,33	2,32	16
22	7,5	28	13	21	M 6	5,3	4	10	NIP 4 MZ	3	8	2,33	2,32	
25	8	32,8	18	24	M 8	6,6	5	11	NIP 4 MZ	–	8	3,65	3,45	20
25	8	32,8	18	24	M 8	6,6	5	11	NIP 4 MZ	4	8	3,65	3,45	
30	9	40	22	29	M10	8,4	6	15	NIP 5 MZ	–	8	6,4	6,5	25
30	9	40	22	29	M10	8,4	6	15	NIP 5 MZ	5	8	6,4	6,5	
35	10	44,7	22	34	M10	8,4	6	15	NIP 5 MZ	–	8	9,6	9	30
35	10	44,7	22	34	M10	8,4	6	15	NIP 5 MZ	5	8	9,6	9	

Linear ball bearing units

open design
contact seals on both sides

Series KTSO...-PP-AS
KTSOS...-PP-AS

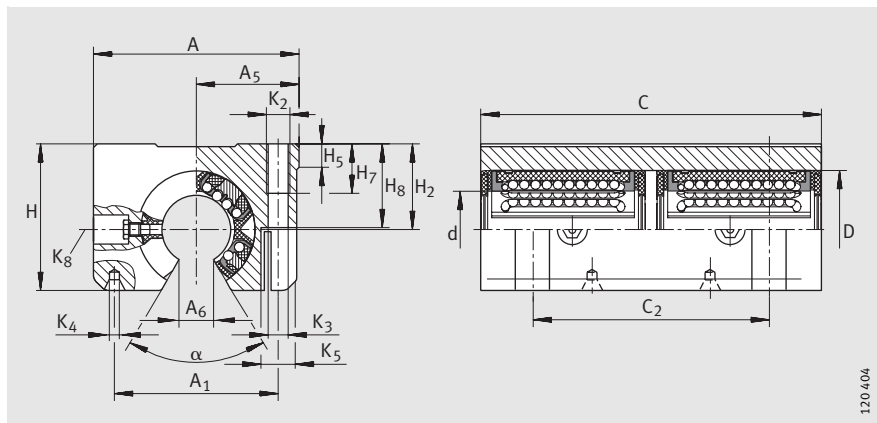

KTSO...-PP-AS

Dimension table · Dimensions in mm

Shaft diameter d	Series		Mass m ≈kg	Dimensions				Mounting dimensions					
	KTSO...-PP-AS	KTSOS...-PP-AS		d	A	C	H	A ₁	A ₅	A ₆ ¹⁾	C ₂ ²⁾	C ₃ ²⁾	D
	Designation	Designation						±0,15	±0,01		±0,15		
12	KTSO12-PP-AS	–	0,176	12	43	70	28	32	21,5	6,5	56	24	22
	–	KTSOS12-PP-AS	0,18	12	43	70	28	32	21,5	6,5	56	24	22
16	KTSO16-PP-AS	–	0,34	16	53	78	35	40	26,5	8,9	64	26	26
	–	KTSOS16-PP-AS	0,34	16	53	78	35	40	26,5	8,9	64	26	26
20	KTSO20-PP-AS	–	0,51	20	60	96	42	45	30	9,2	76	33	32
	–	KTSOS20-PP-AS	0,51	20	60	96	42	45	30	9,2	76	33	32
25	KTSO25-PP-AS	–	1,03	25	78	122	51	60	39	11,9	94	44	40
	–	KTSOS25-PP-AS	1,03	25	78	122	51	60	39	11,9	94	44	40
30	KTSO30-PP-AS	–	1,8	30	87	142	60	68	43,5	14,3	106	54	47
	–	KTSOS30-PP-AS	1,8	30	87	142	60	68	43,5	14,3	106	54	47

1) Dimensions A₆ on diameter d.

2) Dimensions and lubrication hole symmetrical with bearing width C.

3) For fixing screws to EN ISO 4762-8.8.
If there is a possibility of settling, the fixing screws should be secured against rotation.

4) Lubrication nipple.

5) The basic load ratings apply only to hardened (670 HV + 170 HV) and ground shaft raceways.
Basic load ratings in accordance with DIN 636-1.

6) Centring hole to DIN 332, type A.

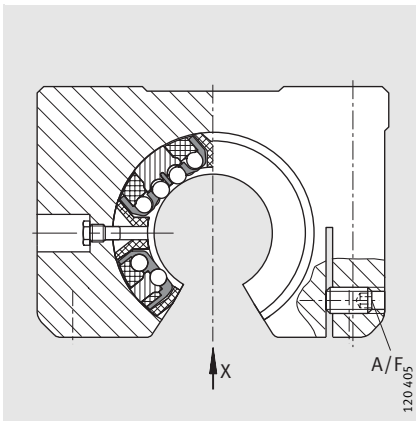

KTSOS...-PP-AS
(same dimensions as KTSO...-PP-AS)

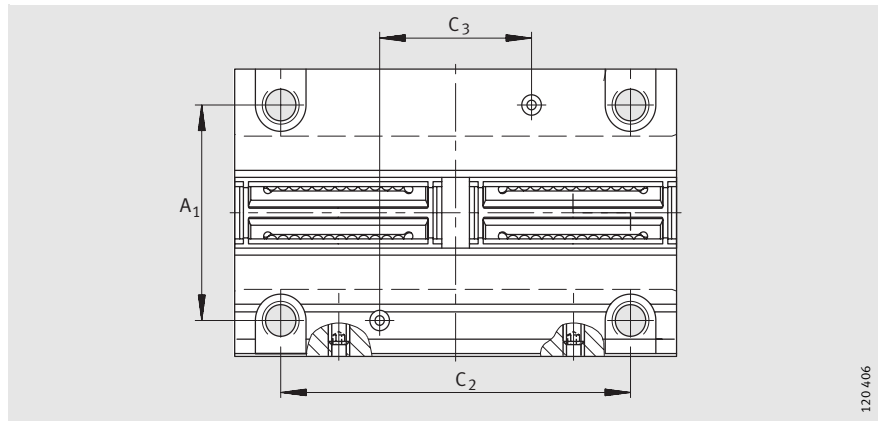

View X (rotated 90°)

120406

H ₂ +0,008 -0,016	H ₅	H ₇	H ₈	K ₂	K ₃ ³⁾	K ₄ ⁶⁾	K ₅ ³⁾	K ₈ ⁴⁾	A/F	α Degrees	Ball rows Quantity	Basic load ratings ⁵⁾		Shaft diameter d
												dyn. C _{max} kN	stat. C _{0 max} kN	
18	6,1	11	16,5	M 5	4,3	1,6×3,35	8	NIP 4 MZ	–	66	6	1,46	1,62	12
18	6,1	11	16,5	M 5	4,3	1,6×3,35	8	NIP 4 MZ	2,5	66	6	1,46	1,62	
22	7,5	13	21	M 6	5,3	1,6×3,35	10	NIP 4 MZ	–	68	6	2,33	2,32	16
22	7,5	13	21	M 6	5,3	1,6×3,35	10	NIP 4 MZ	2,5	68	6	2,33	2,32	
25	8	18	24	M 8	6,6	2,0×4,25	11	NIP 4 MZ	–	55	6	3,65	3,45	20
25	8	18	24	M 8	6,6	2,0×4,25	11	NIP 4 MZ	2,5	55	6	3,65	3,45	
30	8,8	22	29	M10	8,4	2,5×5,3	15	NIP 5 MZ	–	57	6	6,4	6,5	25
30	8,8	22	29	M10	8,4	2,5×5,3	15	NIP 5 MZ	3	57	6	6,4	6,5	
35	9,7	22	34	M10	8,4	2,5×5,3	15	NIP 5 MZ	–	57	6	9,6	9	30
35	9,7	22	34	M10	8,4	2,5×5,3	15	NIP 5 MZ	3	57	6	9,6	9	

Linear ball bearing units

Light range – metric sizes

sealed, greased,
with relubrication facility

Series KGSC...-PP-AS
KGSCS...-PP-AS

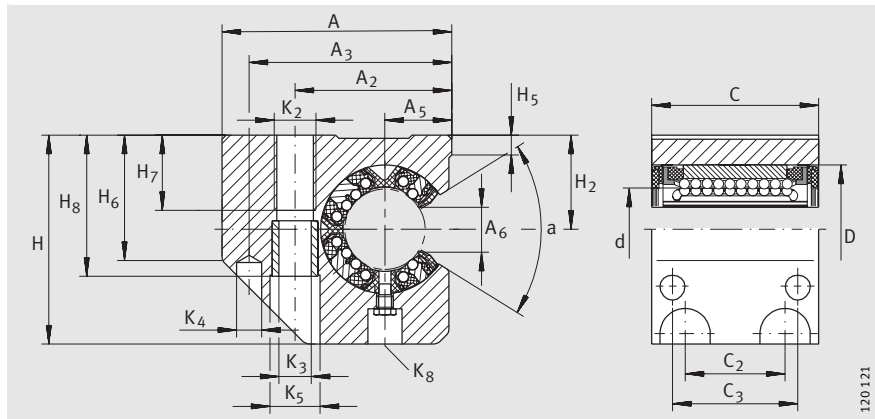

KGSC...-PP-AS

Dimension table · Dimensions in mm

Shaft diameter d	Series		Mass m ≈kg	Dimensions				Mounting dimensions					
	KGSC...-PP-AS Designation	KGSCS...-PP-AS Designation		d	A	C	H	A ₂ ±0,15	A ₃	A ₅ ±0,01	A ₆ ¹⁾	C ₂ ²⁾ ±0,15	C ₃ ²⁾
20	KGSC20-PP-AS	–	0,35	20	60	47	60	39	51	17	9,2	30	36
	–	KGSCS20-PP-AS	0,35	20	60	47	60	39	51	17	9,2	30	36
25	KGSC25-PP-AS	–	0,68	25	75	58	72	49	64	21	12	36	45
	–	KGSCS25-PP-AS	0,68	25	75	58	72	49	64	21	12	36	45
30	KGSC30-PP-AS	–	1	30	86	68	82	59	76	25	14,3	42	52
	–	KGSCS30-PP-AS	1	30	86	68	82	59	76	25	14,3	42	52
40	KGSC40-PP-AS	–	1,8	40	110	80	100	75	97	32	18,8	48	60
	–	KGSCS40-PP-AS	1,8	40	110	80	100	75	97	32	18,8	48	60
50	KGSC50-PP-AS	–	2,9	50	127	100	115	88	109	38	22,7	62	80
	–	KGSCS50-PP-AS	2,9	50	127	100	115	88	109	38	22,7	62	80

1) Dimension A₆ on diameter d.

2) Dimension C₂ and lubrication hole symmetrical with bearing width C.

3) Centring for dowel hole.

4) For fixing screws to EN ISO 4762-8.8.

If there is a possibility of settling, the fixing screws should be secured against rotation.

5) The basic load ratings apply only to hardened (670 HV + 170 HV) and ground shaft raceways.

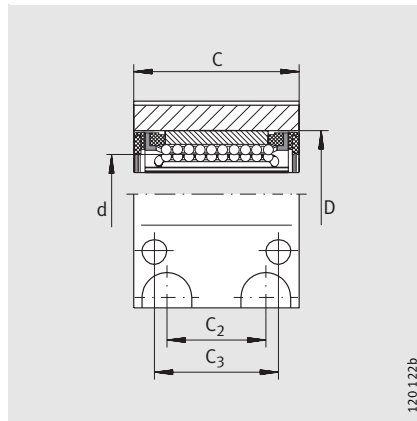
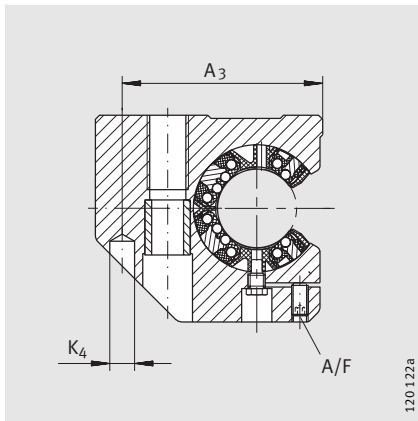

KGSCS.-PP-AS

D	H ₂ +0,008 -0,016	H ₅	H ₆	H ₇	H ₈	K ₂	K ₃ ³⁾	K ₄ ⁴⁾	K ₅ ³⁾	K ₈ ²⁾	A/F	α Degrees	Ball rows Quantity	Basic load ratings ⁵⁾		Shaft diameter d
														dyn. C _{max} kN	stat. C _{0max} kN	
32	30	8,3	37,5	18	42,6	M10	8,4	6	15	NIP 4 MZ	–	55	6	2,2	1,73	20
32	30	8,3	37,5	18	42,6	M10	8,4	6	15	NIP 4 MZ	2,5	55	6	2,2	1,73	
40	35	8,2	45	22	50,6	M12	10,5	8	18	NIP 5 MZ	–	57	6	3,95	3,25	25
40	35	8,2	45	22	50,6	M12	10,5	8	18	NIP 5 MZ	3	57	6	3,95	3,25	
47	40	9	52	29	55,6	M16	13,5	10	20	NIP 5 MZ	–	57	6	5,9	4,5	30
47	40	9	52	29	55,6	M16	13,5	10	20	NIP 5 MZ	3	57	6	5,9	4,5	
62	45	9,5	60	36	67,6	M20	15,5	12	24	NIP 5 MZ	–	56	6	10,2	7,2	40
62	45	9,5	60	36	67,6	M20	15,5	12	24	NIP 5 MZ	4	56	6	10,2	7,2	
75	50	8,6	70	36	78,8	M20	17,5	12	26	NIP 6 MZ	–	54	6	15,1	10,4	50
75	50	8,6	70	36	78,8	M20	17,5	12	26	NIP 6 MZ	5	54	6	15,1	10,4	

Linear ball bearing units

Light range – metric sizes

sealed, greased,
with relubrication facility

Series KTFS...-PP-AS

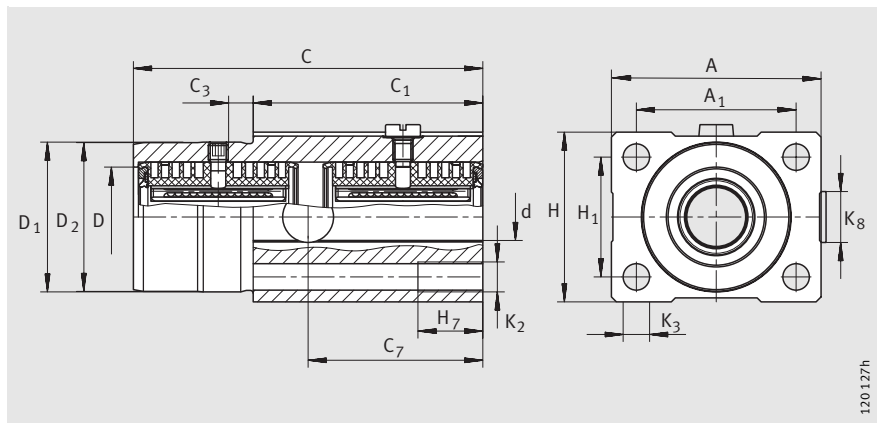

KTFS...-PP-AS

Dimension table · Dimensions in mm

Shaft diameter d	Series KTFS...-PP-AS Designation	Mass m ≈ kg	Dimensions				Mounting dimensions				
			d	A	C	H	A ₁ ±0,15	C ₁	C ₃	C ₇	D
12	KTFS12-PP-AS	0,2	12	41	70	34	32	40	10	35	20
16	KTFS16-PP-AS	0,3	16	50	78	40	38	50	10	39	24
20	KTFS20-PP-AS	0,5	20	60	96	50	45	60	10	48	30
25	KTFS25-PP-AS	1	25	74	122	60	56	73	10	61	38
30	KTFS30-PP-AS	1,4	30	84	142	70	64	82	10	71	44

1) Recommendation: locating bore D₁ H7.

2) The basic load ratings apply only to hardened (670 HV + 170 HV) and ground shaft raceways.

D ₁ ¹⁾	D ₂	H ₁	H ₇	K ₂	K ₃	K ₈	Ball rows Quantity	Basic load ratings ²⁾		Shaft diameter d
								dyn. C _{max} kN	stat. C _{0 max} kN	
g7	-0,1 -0,3	±0,15								
30	30	24	13	M 6	5,3	M8×1	8	1,46	1,62	12
35	35	28	18	M 8	6,6	M8×1	8	2,33	2,32	16
42	42	35	22	M10	8,4	M8×1	8	3,65	3,45	20
52	52	42	26	M12	10,5	M8×1	8	6,4	6,5	25
61	61	50	35	M16	13,5	M8×1	8	9,6	9	30

Shafts

Series W

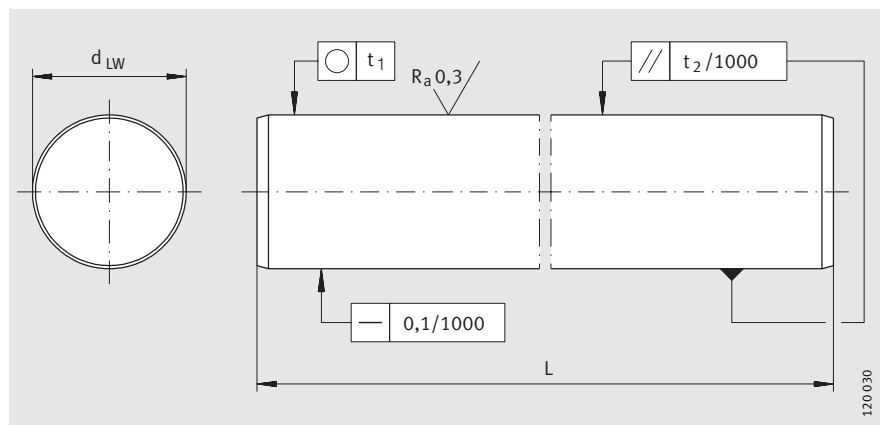

W

Dimension table · Dimensions in mm

Shaft diameter d_{LW}	Designation	Mass m kg/m	Length L_{max}	Tolerances in μm			Roundness t_1 μm	Parallelism $t_2^{2)}$ μm	Surface hardness depth $R_{ht}^{3)}$ min.
				Standard tolerance h6	Special tolerances ¹⁾				
					j5	f7			
5	W5	0,15	3 600	0- 8	-	-	4	5	0,4
6	W6	0,22	4 000	0- 8	-	-	4	5	0,4
8	W8	0,39	4 000	0- 9	-	-	4	6	0,4
10	W10	0,61	4 000	0- 9	-	-	4	6	0,4
12	W12	0,89	6 000	0-11	+5-3	-16-34	5	8	0,6
14	W14	1,21	6 000	0-11	+5-3	-16-34	5	8	0,6
15	W15	1,37	6 000	0-11	-	-16-34	5	8	0,6
16	W16	1,57	6 000	0-11	+5-3	-16-34	5	8	0,6
18	W18	1,98	6 000	0-11	-	-16-34	5	8	0,6
20	W20	2,45	6 000	0-13	+5-4	-20-41	6	9	0,9
24	W24	3,55	6 000	0-13	-	-	6	9	0,9
25	W25	3,83	6 000	0-13	+5-4	-20-41	6	9	0,9
30	W30	5,51	6 000	0-13	+5-4	-20-41	6	9	0,9
32	W32	6,3	6 000	0-16	-	-25-50	7	11	1,5
40	W40	9,8	6 000	0-16	+6-5	-	7	11	1,5
50	W50	15,3	6 000	0-16	+6-5	-	7	11	1,5
60	W60	22,1	6 000	0-19	-	-	8	13	2,2
80	W80	39,2	6 000	0-19	-	-	8	13	2,2

¹⁾ Only for shafts made from quenched and tempered steel.

²⁾ Measured diameter variation.

³⁾ According to DIN 6 773, Part 3.

Recommended threaded holes

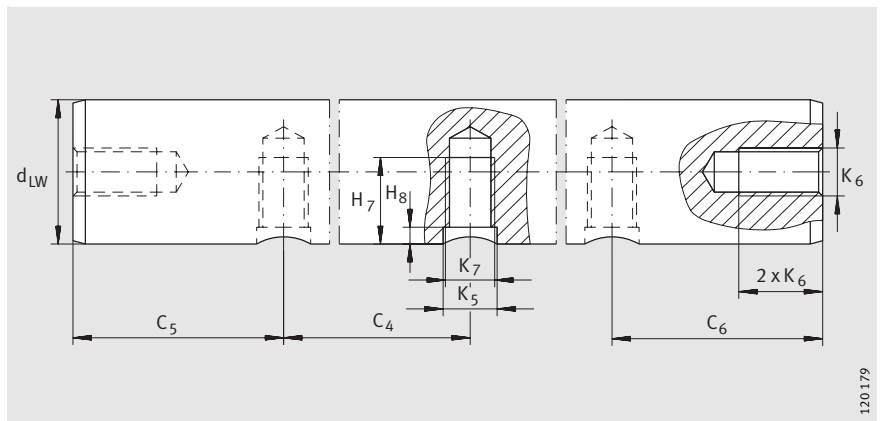

Recommended threaded holes for shafts W

Dimension table · Dimensions in mm

Shaft diameter ¹⁾	Axial threaded hole										Radial threaded hole							
											Dimensions							
	K ₆		C ₄				C _{5 min} , C _{6 min} ²⁾		3 × K ₆ + K ₇									
						03		04-05										
W8	M3	-	-	-	-	-	-	-	-	-	-	-	-	-	-	-	-	-
W10	M3	M4	-	-	-	-	-	-	-	-	-	-	-	-	-	-	-	-
W12	-	M4	M5	-	-	-	-	-	-	75	-	120	10	-	7	2	5	M4
W14	-	M4	M5	M6	-	-	-	-	-	-	-	-	-	-	-	-	-	-
W15	-	-	M5	M6	M8	-	-	-	-	-	-	-	-	-	-	-	-	-
W16	-	-	M5	M6	M8	-	-	-	-	75	100	150	15	-	9	2,5	6	M5
W18	-	-	-	M6	M8	M10	-	-	-	-	-	-	-	-	-	-	-	-
W20	-	-	-	-	-	-	-	-	-	-	-	150	15	-	9	2,5	6	M5
W20	-	-	-	M6	M8	M10	-	-	-	75	100	150	15	-	11	3	7	M6
W24	-	-	-	-	M8	M10	M12	-	-	-	-	-	-	-	-	-	-	-
W25	-	-	-	-	-	-	-	-	-	-	-	150	15	-	11	3	7	M6
W25	-	-	-	-	M8	M10	M12	-	-	75	120	200	15	-	15	3	9	M8
W30	-	-	-	-	-	-	-	-	-	-	-	150	15	-	11	3	7	M6
W30	-	-	-	-	-	M10	M12	M16	-	-	100	150	200	20	17	3,5	11	M10
W32	-	-	-	-	-	M10	M12	M16	-	-	-	-	-	-	-	-	-	-
W40	-	-	-	-	-	M10	M12	M16	-	-	150	200	300	20	19	4	11	M10
W40	-	-	-	-	-	M10	M12	M16	-	-	100	-	-	20	21	4	13	M12
W50	-	-	-	-	-	-	-	-	-	-	-	150	20	-	19	4	11	M10
W50	-	-	-	-	-	-	M12	M16	M20	-	-	200	300	20	21	4	13	M12
W50	-	-	-	-	-	-	M12	M16	M20	-	100	-	-	20	25	4	15	M14
W60	-	-	-	-	-	-	-	M16	M20	M24	-	-	-	-	-	-	-	-
W80	-	-	-	-	-	-	-	M16	M20	M24	-	-	-	-	-	-	-	-

1) For dimensions, see page 22.

2) C₅ and C₆ are dependent on the shaft length. For versions with hole patterns 04 and 05, the axial threaded hole must be taken into consideration

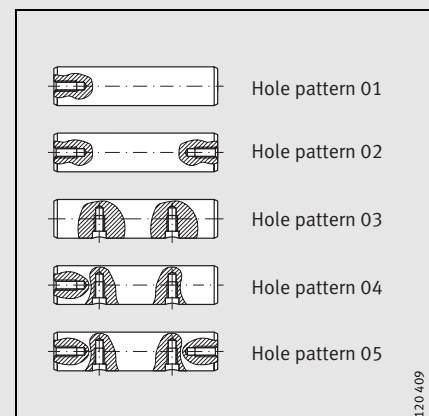

Schaeffler KG

Linear Technology Division
Berliner Strasse 134
66424 Homburg/Saar (Germany)
Internet www.ina.com
E-Mail info.linear@schaeffler.com

In Germany:

Phone 0180 5003872
Fax 0180 5003873

From Other Countries:

Phone +49 6841 701-0
Fax +49 6841 701-625

Every care has been taken to ensure the correctness of the information contained in this publication but no liability can be accepted for any errors or omissions. We reserve the right to make changes in the interest of technical progress.

© Schaeffler KG · 2006, June

This publication or parts thereof may not be reproduced without our permission.

MAI 71